

1. Features

- n $R_{DS(on)}=1.0\ \Omega$ @ $V_{gs}=10V$
- n RoHS compliant
- n Low on resistance
- n Low gate charge(Typical 16.3nC)
- n Peak current vs pulse width curve

2. Applications

- n Adaptor
- n Charger
- n SMPS standby power

3.Symbol

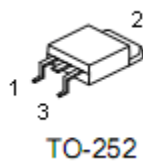
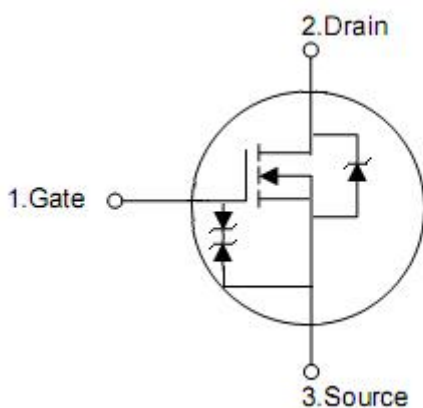

Pin	Function
1	Gate
2	Drain
3	Source

4. Absolute maximum ratings

Parameter	Symbol	Rating	Units
Drain-source voltage	V_{DSS}	550	V
Continuous drain current $T_C=25\text{ }^\circ\text{C}$	I_D	5.0	A
Continuous drain current $T_C=100\text{ }^\circ\text{C}$		3.0	A
Pulsed drain current, $V_{GS}@10V$ (note1)	I_{DM}	20	A
Power dissipation ($T_C=25\text{ }^\circ\text{C}$)	P_D	61.09	W
Derating factor above $25\text{ }^\circ\text{C}$		0.49	W/ $^\circ\text{C}$
Gate-source voltage	V_{GS}	± 20	V
Single pulse avalanche energy (note2)	E_{AS}	161	mJ
Avalanche energy, repetitive (note1)	E_{AR}	7.6	mJ
Avalanche Current (note1)	I_{AR}	5.0	A
Peak diode recovery dv/dt (note3)	dv/dt	4.5	V/ns
Gate-source ESD(HBM-C=100pF,R=1.5K Ω)	$VE_{SD}(G-S)$	3000	V
Maximum temperature for soldering	T_L	300	$^\circ\text{C}$
Operating junction and storage temperature range	T_J, T_{STG}	150,-55 to150	$^\circ\text{C}$

5. Thermal characteristics

Symbol	Parameter	Rating	Unit
$R_{\theta JA}$	Thermal Resistance, Junction-to-Ambient	62.5	$^\circ\text{C}/\text{W}$
$R_{\theta JC}$	Thermal Resistance, Junction-to-Case	1.65	$^\circ\text{C}/\text{W}$
$R_{\theta JS}$	Thermal Resistance, Case-to-Sink Typ.	0.5	$^\circ\text{C}/\text{W}$

6. Electrical characteristics

 (T_J=25°C, unless otherwise specified)

Parameter	Symbol	Test Conditions	Min	Typ	Max	Units
Drain-source breakdown voltage	BV _{DSS}	V _{GS} =0V, I _{DS} =250μA	550	-	-	V
Breakdown voltage temperature coefficient, Figure 11	ΔBV _{DSS} /ΔT _J	Reference to 25°C I _D =250uA		0.61		V/°C
Drain-source leakage current	I _{DSS}	V _{DS} =500V, V _{GS} =0V	-	-	1	μA
		V _{DS} =400V, V _{GS} =0V T _J =125°C	-	-	10	
Gate threshold voltage, Figure 12	V _{GS(th)}	V _{DS} =V _{GS} , I _D =250μA	2	-	4	V
Gate-source forward leakage	I _{GSS}	V _{GS} =20V	-	-	1	uA
Gate-source reverse leakage		V _{GS} =-20V	-	-	-1	
Static drain-source on-resistance Figure 9 and 10	R _{DS(on)}	V _{GS} =10V, I _D =2.5A	-	1.0	1.2	Ω
Forward transconductance	g _{fs}	V _{DS} =40V, I _D =2.5A (note4)	-	3	-	S
Input capacitance	C _{iss}	V _{DS} =25V, V _{GS} =0V f=1MHz	-	682	-	pF
Output capacitance	C _{oss}		-	23	-	
Reverse transfer capacitance	C _{rss}		-	9	-	
Turn-on delay time	t _{d(on)}	V _{DD} =275V, I _D =5A, R _G =25Ω, (note4,5)	-	25	-	ns
Rise time	t _r		-	23	-	
Turn-off delay time	t _{d(off)}		-	92.5	-	
Fall time	t _f		-	47	-	
Total gate charge	Q _g	V _{DD} =440V, I _D =5A, V _{GS} =10V, (note4,5)	-	16.3	-	nC
Gate-source charge	Q _{gs}		-	3.6	-	
Gate-drain charge	Q _{gd}		-	5.1	-	
Continuous source current (body biode)	I _S	Integral pn-diode in MOSFET	-	-	5	A
Maximum pulsed current (body biode)	I _{SM}		-	-	20	
Diode forward voltage	V _{SD}	I _S =5A, V _{GS} =0V	-	-	1.4	V
Reverse recovery time	t _{rr}	I _F =5A, V _{GS} =0V	-	312	-	nS
Reverse recovery charge	Q _{rr}	di/dt=100A/μs (note4)	-	2.1	-	uC

Notes:

1. Repetitive Rating : Pulse width limited by maximum junction temperature
2. L = 12mH, I_{AS} = 5.0A, V_{DD} = 50V, R_G= 25Ω, Starting T_J= 25°C
3. I_{SD}≤5.0A, di/dt ≤200A/μs, V_{DD} ≤BV_{DSS}, Starting T_J= 25°C
4. Pulse Test : Pulse width ≤300us, Duty cycle ≤2%
5. Essentially independent of operating temperature

7. Typical operating characteristics

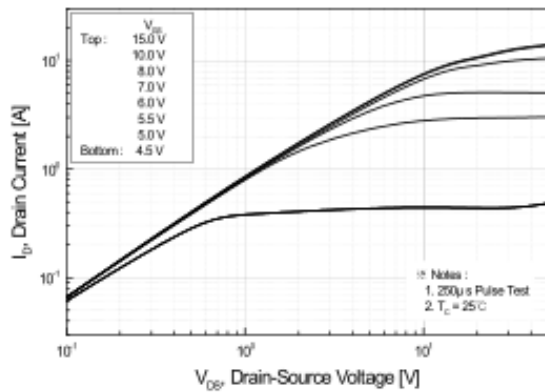

Figure 1. On-Region Characteristics

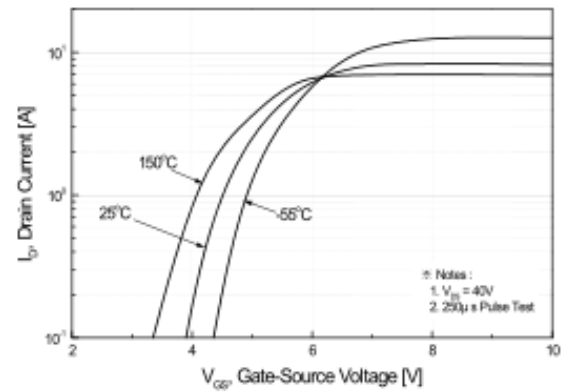

Figure 2. Transfer Characteristics

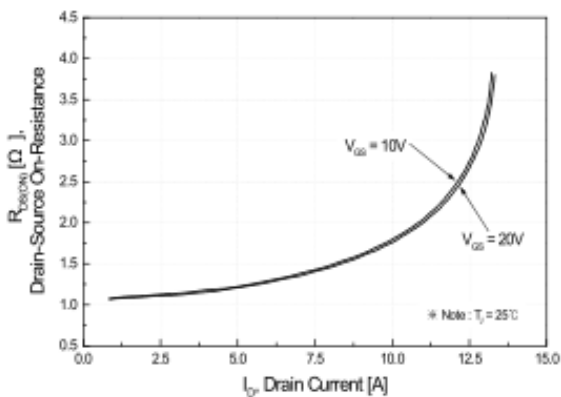

Figure 3. On-Resistance Variation vs Drain Current and Gate Voltage

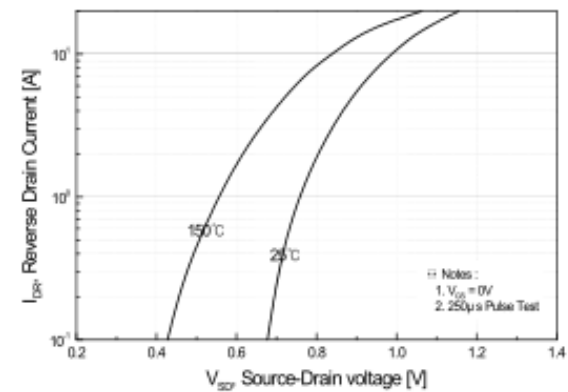

Figure 4. Body Diode Forward Voltage Variation with Source Current and Temperature

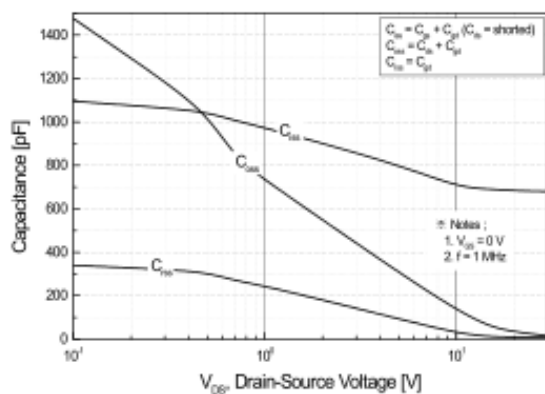

Figure 5. Capacitance Characteristics

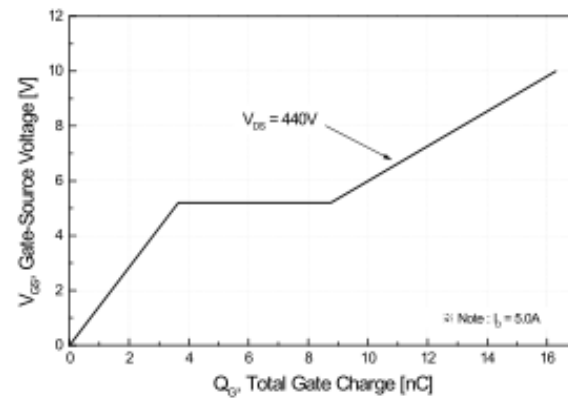

Figure 6. Gate Charge Characteristics

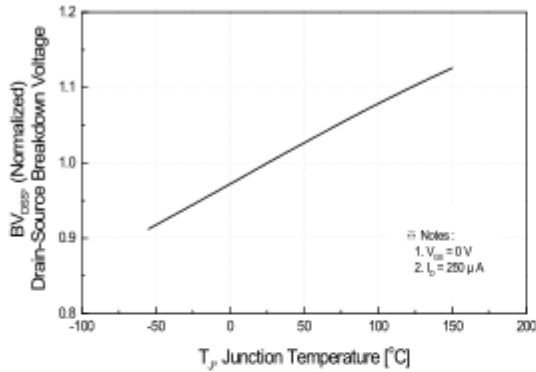

Figure 7. Breakdown Voltage Variation vs Temperature

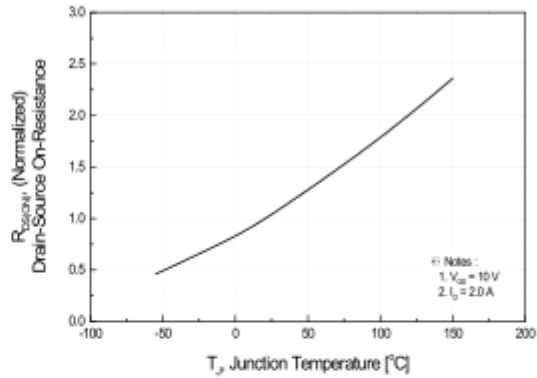

Figure 8. On-Resistance Variation vs Temperature

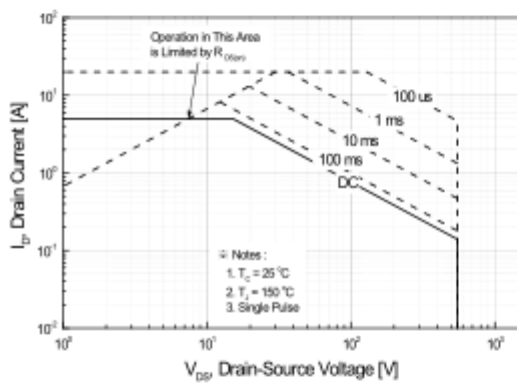

Figure 9. Maximum Safe Operating Area

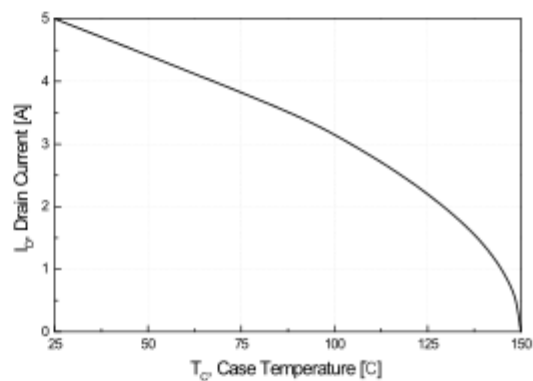

Figure 10. Maximum Drain Current vs Case Temperature

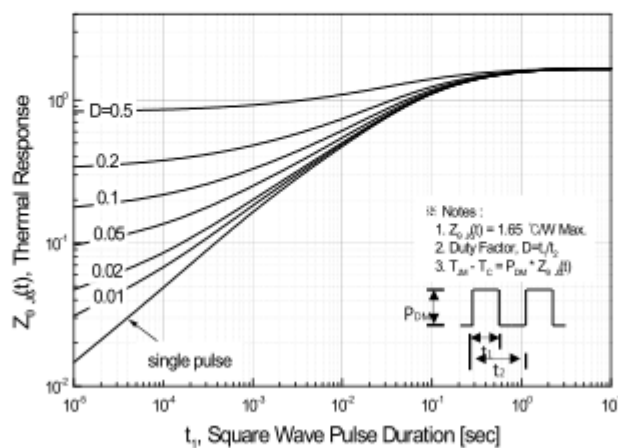
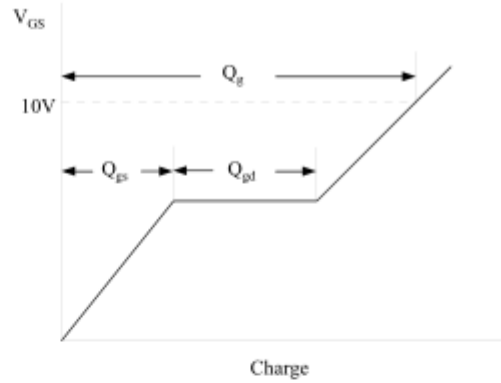
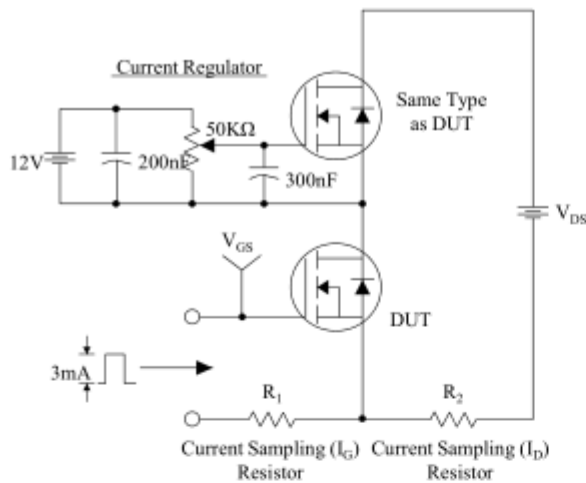
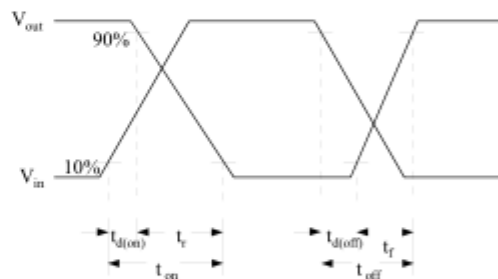
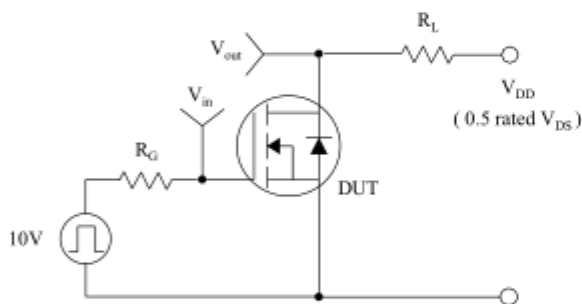

Figure 11. Transient Thermal Response Curve

Gate Charge Test Circuit & Waveform



Resistive Switching Test Circuit & Waveforms



Unclamped Inductive Switching Test Circuit & Waveforms

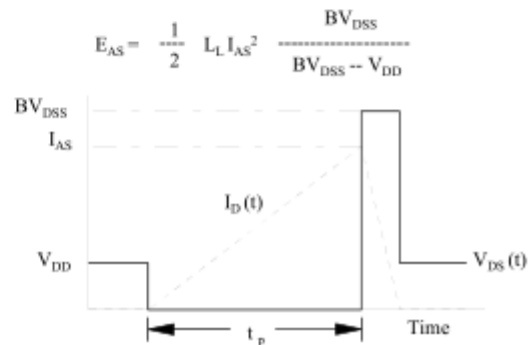
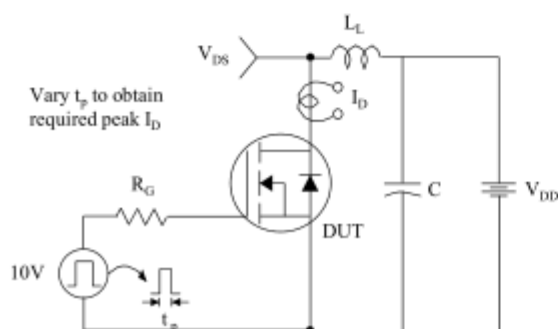

Gate Charge Test Circuit & Waveform

